



Adres : 1201 Sokak No:89 Ostim Yenimahalle / ANKARA

Telefon : (0312) 394 64 77

Faks : (0312) 394 64 76

E-Mail : mcb@mcbmuhendislik.com

BLASTING SYSTEMS



Turbine blasting systems

Air blasting systems

Automatic Painting plants

AIR BLASTING SYSTEMS

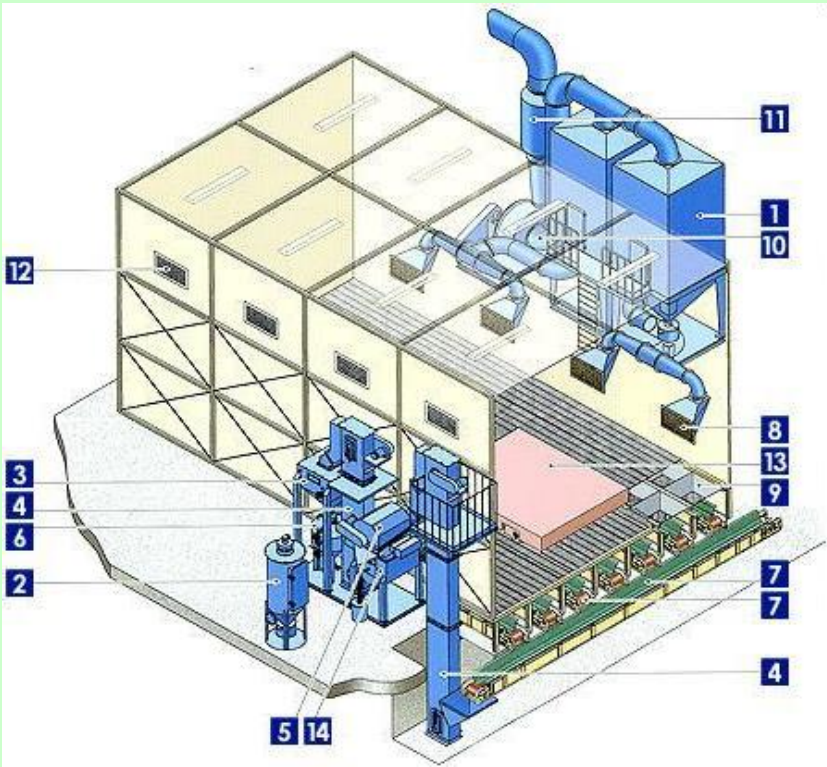

- 1, Dust Collector
- 2, Cyclone Separator
- 3, Sand (shot) Storage Hopper
- 4, Bucket elevator
- 5, Primary separator
- 6, AC type air blast machine
- 7, Conveyor , screw conveyor
- 8, Dust Outlet
- 9, Waffle Floor Hopper
- 10, Blower
- 11, Silencer
- 12, Air inlet
- 13, Rail Work Trolley
- 14, Secondary separator

System consist of the 5 main unit

- Cabinet
- Recycling system
- Air filter
- Blasting system
- Trolley

AIR BLASTING SYSTEMS

CABINET

Cabinet dimensions changeable according to the customer requires, cabinet inner surfaces coating to the changeable abrasive resist rubber. Under of the cabinet special design abrasive wiper paddle by means of pneumatic cylinder driven . Paddle upper side closed to screen for safety working

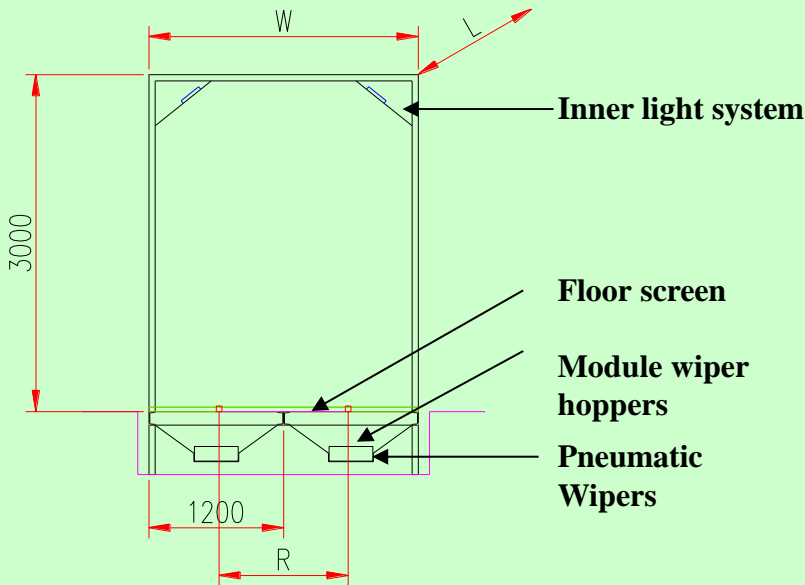

Cabinet section

Cabinet dimension				
W (Cabinet width)	mm	2400	3600	4800
R (Rail width)	mm	1200	2400	3600
L (Cabinet length)	m	6, 12, 18, 24		

Upper table shown only standard cabinet sizes , cabinet system and size changeable according to the customer requires

AIR BLASTING SYSTEMS

RECYCLING SYSTEM

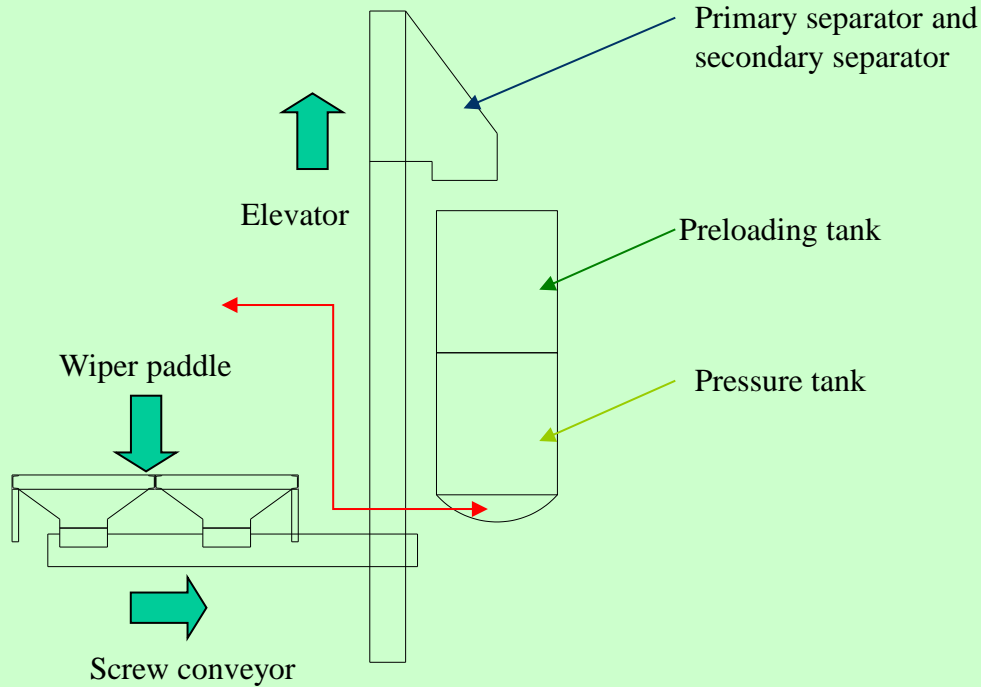

Schema of recycling system

Primary separator : Screening to the abrasive for separated biggest part

Secondary separator : Secondary separator cleaning to the abrasive from dust and unusable particulars by means of air

Preloading tank : After of the separation process abrasive stock age to the this tank until end of operation, after the operation abrasive discharge to the pressure tank

AIR BLASTING SYSTEMS

AIR FILTER

cartridge type, jet pulse filter using in this system , filter capacity changeable to the cabinet size.

Minimum fan capacity m ³ /h – kW.				
W / L	6m	12m	18m	24m
2400 mm	3456 / 5.5 kW	6912 / 5.5 kW	10368 / 7.5 kW	13824 / 11 kW.
3600 mm	5184 / 5.5 kW.	10368 / 7.5 kW	15552 / 18.5 kW	20736 / 15 kW
4800 mm	6912 / 5.5 kW.	13824 / 11 kW.	20736 / 15 kW	27648 / 22.5 kW

Minimum filter size m ²				
W / L	6m / Model	12m / Model	18m / Model	24m / Model
2400 mm	100 / MF20	100 / MF20	200 / MF20	300 / MF30
3600 mm	100 / MF20	200 / MF20	300 / MF30	400 / MF40
4800 mm	200 / MF20	300 / MF30	400 / MF40	500 / MF50





İvedik Organize Sanayi Bölgesi 24.Cad. No:112
Ankara / TURKEY

Tel : 90 312 354 64 77 Faks : 90 312 354 64 76 Mobil : 0 533 441 12 61

AIR BLASTING SYSTEMS

Cabinet Price				
Cabinet W / L	6m	12m	18m	24m
2400mm				
3600mm				
4800mm				
All hosing included in these prices				

Filter price		
MF20	7.500 Euro	Filter , fan , air valves and piping included
MF30	8.500 Euro	
MF40	9.800 Euro	
MF50	10.800 Euro	

Cartridges DONALDSON TORIT mark USA

Filter price		
MF20	9.000 Euro	Filter , fan , air valves and piping included
MF30	9.500 Euro	
MF40	12.600 Euro	
MF50	14.800 Euro	
Cartridges local products		

AIR BLASTING SYSTEMS

BLASTING SYSTEM EQUIPMENTS

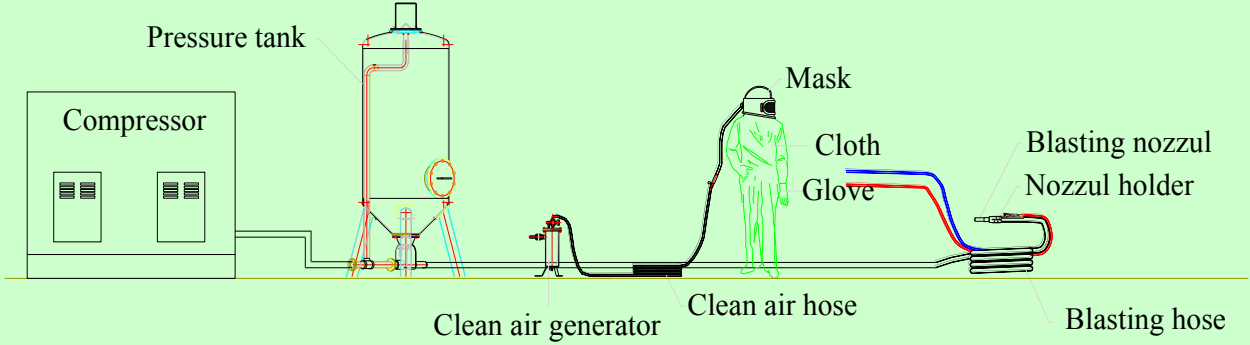

PRESSURE TANK

TANK	COMPRESSOR Power	MAX. OPERATOR	Performance	Price
200 LT.	45 KW	1 Ea.	High	1350 Euro
500 LT.	75 KW	2 Ea.	High	2600 Euro
500 LT.	90 KW	2 Ea.	Very high	2600 Euro
2000 LT.	110 KW	4 Ea.	high	6200 Euro
2000 LT.	160 KW	4 Ea.	Very high	6200 Euro





İvedik Organize Sanayi Bölgesi 24.Cad. No:112
Ankara / TURKEY

Tel : 90 312 354 64 77 Faks : 90 312 354 64 76 Mobil : 0 533 441 12 61

AIR BLASTING SYSTEMS

COMPRESSOR

MODEL DALGAKIRAN		Max. Nozzle Each	
DVK-60	45 KW	1 Ea.	19.700 EU.
DVK -100B	75 KW	2 Ea.	26.800 EU.
DVK -125	90 KW	2 Ea.	27.900 EU.
DVK -150	110 KW	2 Ea.	34.600 EU.
DVK -220	160 KW	4 Ea.	38.300 EU.

MODEL	BAR	Air capacity	Power Kw / hp.	Air store age tank	Air dryer
DVK 100B	7.5	13.0	75/100	2000 l	Included
	10	10.9			
	13	09.0			
DVK 125	7.5	15.8	90/125	2000 l	Included
	10	13.5			
	13	11.0			
DVK 150	7.5	18.8	110/150	3000 l	Included
	10	16.5			
	13	14.0			
DVK 220	7.5	27.4	160/220	3000 l	Included
	10	23.0			
	13	19.5			

Compressor price changeable according to the compressor mark





İvedik Organize Sanayi Bölgesi 24.Cad. No:112

Ankara / TURKEY

Tel : 90 312 354 64 77 Faks : 90 312 354 64 76 Mobil : 0 533 441 12 61

AIR BLASTING SYSTEMS

Nozzul

Nozzle performance						
Nozzle diameter		8	9.5	11	12.5	
Air consumption in m ³ /min by 8 bar		6,6	9,0	11,6	16,1	
Average abrasive consumption in kg/m ²	SA 2	35	32	29	28	
	SA 2.5	51	46	42	40	
	SA 3	68	62	56	54	
Average performance in m ² /h	SA 2	15	21	28	38	
	SA 2.5	9	14	21	27	
	SA 3	6	9	13	17	

Accessories	QTY.	Price
CLEAN AIR GENERATOR This units provided to clean air to the operators, Per unit only three operator air require can supply	1 each	260 Euro
Nozzle diameter 8	1 each	130 Euro
Nozzle diameter 9.5	1 each	140 Euro
Nozzle diameter 11	1 each	150 Euro
Nozzle diameter 12	1 each	160 Euro
Blasting hose	1 m.	9.5 Euro
Glove	1.Set	12 Euro
Cloth – Half size	1.Each	35 Euro
Cloth – Full size	1.Each	115 Euro
Mask	1.Each	175 Euro

AIR BLASTING SYSTEMS

Trolley

Trolley made from steel profile and trolley driven by mean of gearbox. Standard length of trolley 3m. and 6m.

For the long parts can using 2 each 3m. trolley

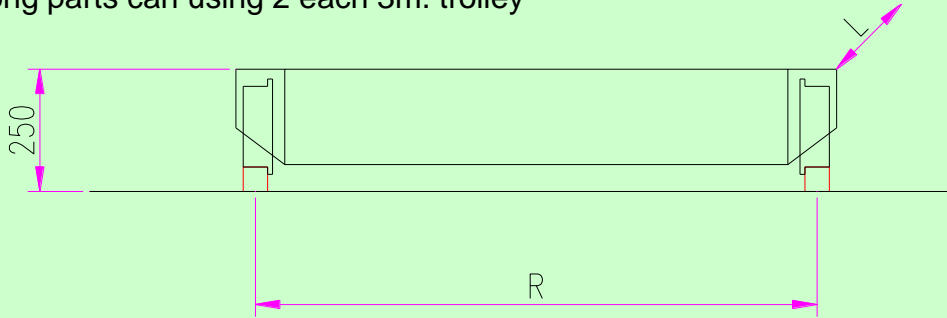

R	L / Power		Load Capacity
1200mm	3 / 0.55kW	6 / 0.75kW	6 Ton
2400mm	3 / 0.75kW	6 / 0.75 kW	6 Ton
3600mm	3 / 1.10kW	6 / 1.10 kW	6 Ton
Driven engine power changeable according to the load capacity			

PRICE LIST			
R mm / L m	3	6	
1200	3000 Euro	3750 Euro	
2400	3600 Euro	4500 Euro	
3600	4250 Euro	5350 Euro	

Electrical system

All system controlled in one control panel , control panel support on the side of cabinet.

All electrical equipments SIEMENS mark.



İvedik Organize Sanayi Bölgesi 24.Cad. No:112
Ankara / TURKEY

Tel : 90 312 354 64 77 Faks : 90 312 354 64 76 Mobil : 0 533 441 12 61

MCB ENGGINERING

SOME REFERANCE

NOKSELsteel pipe A.Ş.	Shot blasting	1 Each
OZBALsteel pipe A.Ş.	Shot blasting	2 Each
HATpipe A.Ş.	Shot blasting	1 Each
EMEK pipe A.Ş.	Shot , Air blasting	2 Each
ERCIYAS A.Ş.	Shot, Air blasting	2 Each
GOKTAS A.Ş.	Shot blasting , painting	1 Each
HER CELIK A.Ş.	Shot blasting, painting	1 Each
UMRAN steel pipe	Shot , air blasting	1 Each



BLASTING SYSTEM & CONCRETE PLANTS